

Question block created by wizard

This exam contains 92 questions.

1. The energy that has been converted into the energy of motion, is known as...

- (a) potential energy.
- (b) kinetic energy.
- (c) newtons energy.

If choice b is selected set score to 1.

2. What is mechanical work?

- (a) The amount of energy transferred by a force.
- (b) The cause to accelerate a mass.
- (c) The rate at which work is performed or energy is transmitted.

If choice a is selected set score to 1.

3. What kind of engine is this?



- (a) Multi spool engine.
- (b) Twin spool engine.
- (c) Single spool engine.

If choice c is selected set score to 1.

4. Which engine has a better stall characteristic?

- (a) Multi spool axial flow engine.
- (b) Single spool axial flow engine.
- (c) Both answers are correct.

If choice a is selected set score to 1.

5. In what unit is the power measured that a turbo-prop engine delivers to the gearbox?

- (a) Shaft Horsepower.
- (b) Foot pounds.

- o (c) Pounds.

If choice a is selected set score to 1.

6. What conditions affect the weight of a given volume of air?

- (a) Pressure, temperature and humidity.
- o (b) Effect of humidity is more pronounced as the effect of pressure and temperature.
- o (c) Pressure, is its only factor, regardless of weight.

If choice a is selected set score to 1.

7. The bypass ratio of a turbofan is the ratio between the air....

- o (a) that goes through the HP compressor and the air that goes through the HP turbine.
- (b) through the bypass and the air through the core engine.
- o (c) through the combustion chamber and the cooling around the combustion chamber.

If choice b is selected set score to 1.

8. The engine data and engine assembly identification plates are attached to the engine.

What data do these plates provide?

- (a) Engine specification as designed by the manufacturer.
- o (b) Aircraft specification as designed by the manufacturer for the engine to be installed.
- o (c) Engine specification as designed by the manufacturer for the aircraft configuration.

If choice a is selected set score to 1.

9. From Boyle's law you can conclude that if a balloon is compressed to half its volume, the pressure in the balloon will be....



- (a) the same.
- (b) the half.
- (c) doubled.

If choice c is selected set score to 1.

10. What will happen in flight if the intake airspeed increases?

- (a) Thrust will not change.
- (b) Thrust will decrease.
- (c) Thrust will increase.

If choice a is selected set score to 1.

11. How is the effectiveness expressed for an engine intake?

- (a) Pressure recovery.
- (b) Engine power.
- (c) Mass airflow.

If choice a is selected set score to 1.

12. A Bellmouth intake is used in helicopters and engine test facilities....

- (a) to accelerate the airflow.
- (b) to slow down the airflow.
- (c) because of the ram effect.

If choice a is selected set score to 1.

13. What shape does a bifurcated intake have?

- (a) First divergent, then convergent towards the rear.
- (b) Divergent from front to rear.
- (c) Convergent from front to rear.

If choice b is selected set score to 1.

14. Which surfaces are always anti-iced on a turboprop engine?

- (a) Intake and propeller blades
- (b) Propeller blades only
- (c) Intake, propeller and spinner

If choice a is selected set score to 1.

15. On an engine with hot air anti-icing, where does the air come from?

- (a) From the engine itself.
- (b) From the aircraft air system.
- (c) From the opposite engine.

If choice a is selected set score to 1.

16. In the axial compressor the flow of air is maintained parallel to...

- (a) the vertical rotation of the compressor blades.
- (b) the compressor centers around the impeller, diffuser and air intake system.
- (c) the compressor shaft.

If choice c is selected set score to 1.

17. Why were swept fan blades developed?



- (a) To decrease the aerodynamic efficiency.
- (b) To increase the aerodynamic efficiency.
- (c) To increase the dynamic efficiency.

If choice b is selected set score to 1.

18. Fan blades are normally...

- (a) cleaned after each flight to maintain efficiency.
- (b) replaceable in moment weighted pairs.
- (c) not replaced on installed engine.

If choice b is selected set score to 1.

19. What is an advantage of titanium Wide Chord Fan Blade Technology?

- (a) The longer life of operation.
- (b) The process generates an internal stiffening structure that greatly increases the strength of the blade.
- (c) The appearance is impressive.

If choice b is selected set score to 1.

20. What are the audible indications of Stall/Surge ?

- (a) Vibration.
- (b) Abnormal noises, rumbles.
- (c) slow to accelerate from idle.

If choice b is selected set score to 1.

21. Compressor bleed valves are normally...

- (a) moving from closed to open during acceleration.
- (b) closed at high power.
- (c) open at high power.

If choice b is selected set score to 1.

22. One of the primary limiting factors on pressure ratio in modern designs is that the:

- (a) air cools down as it is compressed.
- (b) location that the temperature is taken.
- (c) air heats up as it is compressed.

If choice c is selected set score to 1.

23. The can-type combustion chamber is typical of the type used on....

- (a) turbofan and APUs.
- (b) turbojet and turbojet.
- (c) turboshaft and APUs.

If choice c is selected set score to 1.

24. Which combustion chamber is normally used with a centrifugal compressor?

- (a) Turbo-annular combustion chamber.
- (b) Annular combustion chamber.
- (c) Multiple combustion chamber.

If choice c is selected set score to 1.

25. What temperature has the primary zone of the combustion chamber?

- (a) 2000 °C.
- (b) 1500 °C.
- (c) 2000 °F.

If choice a is selected set score to 1.

26. What is the result of the twist in the turbine blades, called stagger angle?

- (a) Lower gas pressure and higher velocity at the tip.
- (b) Relative constant pressure at the tip and higher velocity.

- (c) Same amount of work along the whole blade.

If choice c is selected set score to 1.

27. By using fir-tree fixing, the blade will be...

- (a) free to move slightly at all times to eliminate stresses in the blade root
- (b) fixed to the disk with no clearances.
- (c) free when the engine is stationary and stiffened in the root when the engine rotates

If choice c is selected set score to 1.

28. "When the blade is at the end of its useful life."

In what stage does this creep take place?

- (a) Tertiary.
- (b) Secondary.
- (c) Engine operational for a new engine.

If choice a is selected set score to 1.

29. Over a period of operating time the turbine blades slowly grow in length. This phenomenon is known as...

- (a) case restriction.
- (b) creep.
- (c) case growth.

If choice b is selected set score to 1.

30. What is the function of the inner exhaust cone at the rear face of the turbine disc?

The cone....

- (a) decreases the exhaust area to the rear and maximizes the gas velocity.
- (b) decreases the exhaust area to the rear and lowers the gas velocity.
- (c) increases the exhaust area to the rear and lowers the gas velocity.

If choice c is selected set score to 1.

31. On commercial gas turbine engines the exhaust duct is....

- (a) divergent.
- (b) convergent / divergent.

- (c) convergent.

If choice c is selected set score to 1.

32. A translating cowl moves backwards on either side of the engine thrust reverser.

This exposes...

- o (a) only compressed air from the high pressure compressor.
- (b) cascades.
- o (c) turbine blades.

If choice b is selected set score to 1.

33. Which type of sealing arrangement does a carbon seal have?

- o (a) Using air pressure to minimize oil leakage.
- (b) Full rest contact against a surface.
- o (c) Full contact with casing.

If choice b is selected set score to 1.

34. Why do bearing assemblies often contain a cage?

- (a) To keep the rollers or balls in place.
- o (b) To transmit forces to the raceway.
- o (c) To make sure lubrication is 100%.

If choice a is selected set score to 1.

35. Engine bearing cavities are sealed with labyrinth seals and are supported....

- o (a) with engine oil pressure
- (b) with engine air pressure.
- o (c) in a powder substance to insure longer life support.

If choice b is selected set score to 1.

36. At extreme cold starting conditions the prime limiting factor for fuel is:

- (a) Viscosity.
- o (b) Smoke point.
- o (c) Flashpoint.

If choice a is selected set score to 1.

37. What is the advantage of jet fuel A1, compared to jet fuel A?

- (a) Lower freezing point.
- o (b) Higher freezing point.
- o (c) Higher burning rate.

If choice a is selected set score to 1.

38. What is a difference between Jet A and Jet A-1 fuel?

- o (a) Sulfur mass.
- (b) Freezing point.
- o (c) Fuel density.

If choice b is selected set score to 1.

39. Increasing the flashpoint will make fuel safer but....

- o (a) a hot start will become more difficult.
- (b) a cold start will become more difficult.
- o (c) the fuel consumption will increase drastically.

If choice b is selected set score to 1.

40. An oil gear pump delivers oil in the system....

- o (a) to prevent the fuel from freezing.
- o (b) to prevent the water in the fuel from freezing.
- (c) under pressure.

If choice c is selected set score to 1.

41. When the electronic engine control has to be replaced, what happens with the programming plug?

The programming plug must....

- o (a) be reprogrammed for the new electronic engine control.
- (b) remain with the engine.
- o (c) be renewed.

If choice b is selected set score to 1.

42. What is the purpose of an engine oil system?

- (a) Bearing lubrication and heating fuel.
- (b) Bearing cooling, lubrication and heating fuel.
- (c) Bearing cooling, lubrication and cooling fuel.

If choice b is selected set score to 1.

43. What is the purpose of the air- oil centrifugal breather?

To separate oil from the air mist in the....

- (a) gearbox.
- (b) oil tank.
- (c) suction pump.

If choice a is selected set score to 1.

44. When the pilot moves the fuel control power lever forward, fuel flow is increased. This increase in fuel flow creates increased gas expansion in the combustor chamber.

What is the effect of this gas expansion?

- (a) It raises the level of power in the engine, producing more thrust.
- (b) It lowers the level of temperature in the combustion chamber of the engine. This increases the thrust.
- (c) It raises the level of air flow being metered to the engine by the fuel control unit.

If choice a is selected set score to 1.

45. When on the EICAS the fuel bypass message is indicated, where does the signal come from?

- (a) Low pressure fuel pump bypass valve.
- (b) Differential pressure switch.
- (c) Main pressure fuel pump bypass valve.

If choice b is selected set score to 1.

46. The full authority digital electronic control (FADEC) system is a computer-based engine control system. Each aircraft engine has its own control system.

What is the main component of the FADEC system?

- (a) The engine driven fuel pumps.

- (b) The electronic engine control (EEC).
- o (c) The fuel control unit.

If choice b is selected set score to 1.

47. The low pressure fuel pump is a....

- o (a) gear pump.
- o (b) vane pump.
- (c) centrifugal pump.

If choice c is selected set score to 1.

48. What is the function of linear variable differential transformers (LVDT)?

- (a) Feedback signals.
- o (b) Warning signals.
- o (c) Control signals.

If choice a is selected set score to 1.

49. Thrust lever position is transmitted to the EEC via a thrust lever resolver, as Thrust Lever....

- (a) angle.
- o (b) solenoid energized in a series.
- o (c) cables.

If choice a is selected set score to 1.

50. The turbine cooling system controls the....

- o (a) temperature of the high and low pressure turbine.
- o (b) creep of the turbine blades.
- (c) blade clearance of the high and low pressure turbine.

If choice c is selected set score to 1.

51. What air is supplied to the nacelle zone?

- (a) Fan air.
- o (b) High pressure compressor air.
- o (c) Low pressure turbine air.

If choice a is selected set score to 1.

52. How is the 2.5 bleed valve actuator controlled?

- (a) By the EEC.
- o (b) By the fuel control.
- o (c) By the N1 rpm sensor.

If choice a is selected set score to 1.

53. The engine has sufficient rpm during start-up to accelerate on its own power.

How do you call this speed?

- (a) Self-sustaining speed.
- o (b) Idle speed.
- o (c) Light-up speed.

If choice a is selected set score to 1.

54. A common method of coupling the electrical starter drive to the engine is by means of a...

- o (a) direct shaft to high speed shaft.
- o (b) ratchet on the drive gearbox.
- (c) jaw on the starter.

If choice c is selected set score to 1.

55. The high tension distribution system conducts the high voltage dc from the ignition exciters to the...

- o (a) condenser.
- o (b) compressor case
- (c) igniter plugs.

If choice c is selected set score to 1.

56. Is the depth of the igniter in the combustion chamber important?

- o (a) Yes, but the installation is only important after engine change.
- (b) Yes, the use of correct spacers and gaskets is important.
- o (c) No, because the depth is not critical.

If choice b is selected set score to 1.

- 57.** "Ignition system voltage is dangerously high. Ignition switch must be in off position before removal of any ignition component." This is a warning.

Why?

- (a) Could cause early rotation of the starter.
- (b) The ignition box has to warm up because it extremely cold.
- (c) Because it could result in severe injury to personnel

If choice c is selected set score to 1.

- 58.** Why is the EGT indication very important?

- (a) It is the only engine condition monitoring parameter.
- (b) It gives information about the heaviest loaded part, the turbine.
- (c) It gives a direct relationship to engine power.

If choice b is selected set score to 1.

- 59.** What does engine pressure ratio on a modern turbofan engine indicate?

- (a) The air pressure produced by the compressor.
- (b) The air pressure at the exhaust.
- (c) The pressure ratio across the fan.

If choice c is selected set score to 1.

- 60.** The oil pressure transmitter senses the difference between pressure pump delivery pressure and...

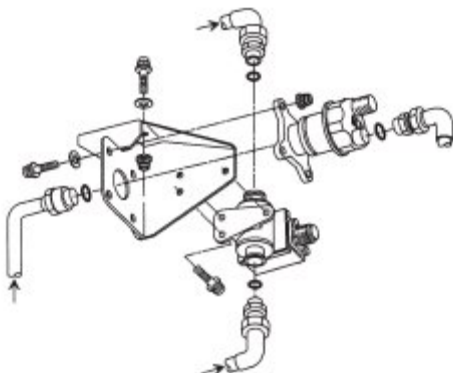

- (a) the ISA parameters.
- (b) the FCOC (Fuel Cooled Oil Cooler).
- (c) the gear box pressure.

If choice c is selected set score to 1.

61. The engine tachometer N2 system senses engine speed.

It displays the speed on EICAS in....

- (a) rpm (revolutions per minute).
- (b) engine pounds of thrust.
- (c) percent.

If choice c is selected set score to 1.

62. Which indication component is using a permanent magnet with three coil assemblies?

- (a) The engine tachometer system.
- (b) The airborne vibration system signal conditioner pick up points.
- (c) The fuel pump pressure indication system.

If choice a is selected set score to 1.

63. Adverse conditions, as far as the engine is concerned, is operation in high ambient temperature and/or high altitude. These are adverse conditions.

Which two systems are available to overcome these conditions?

- (a) Remove the throttle stops for more thrust.
- (b) Water injection and water / methanol injection
- (c) Turbine case cooling and bleed air control.

If choice b is selected set score to 1.

64. The mass flow rate of air through the engine is depending on the density of the air.

A higher mass flow rate results in...

- (a) a greater thrust of the engine.
- (b) a higher engine temperature.
- (c) a lower thrust output.

If choice a is selected set score to 1.

65. The increased thrust is obtained by injecting and burning large quantities of fuel in the specially shaped engine exhaust system. This is referred to as....

- (a) after burner

- (b) rocket pressure outlet nozzle
- (c) hot shot ignition

If choice a is selected set score to 1.

66. What kind of engine is shown in the next picture?

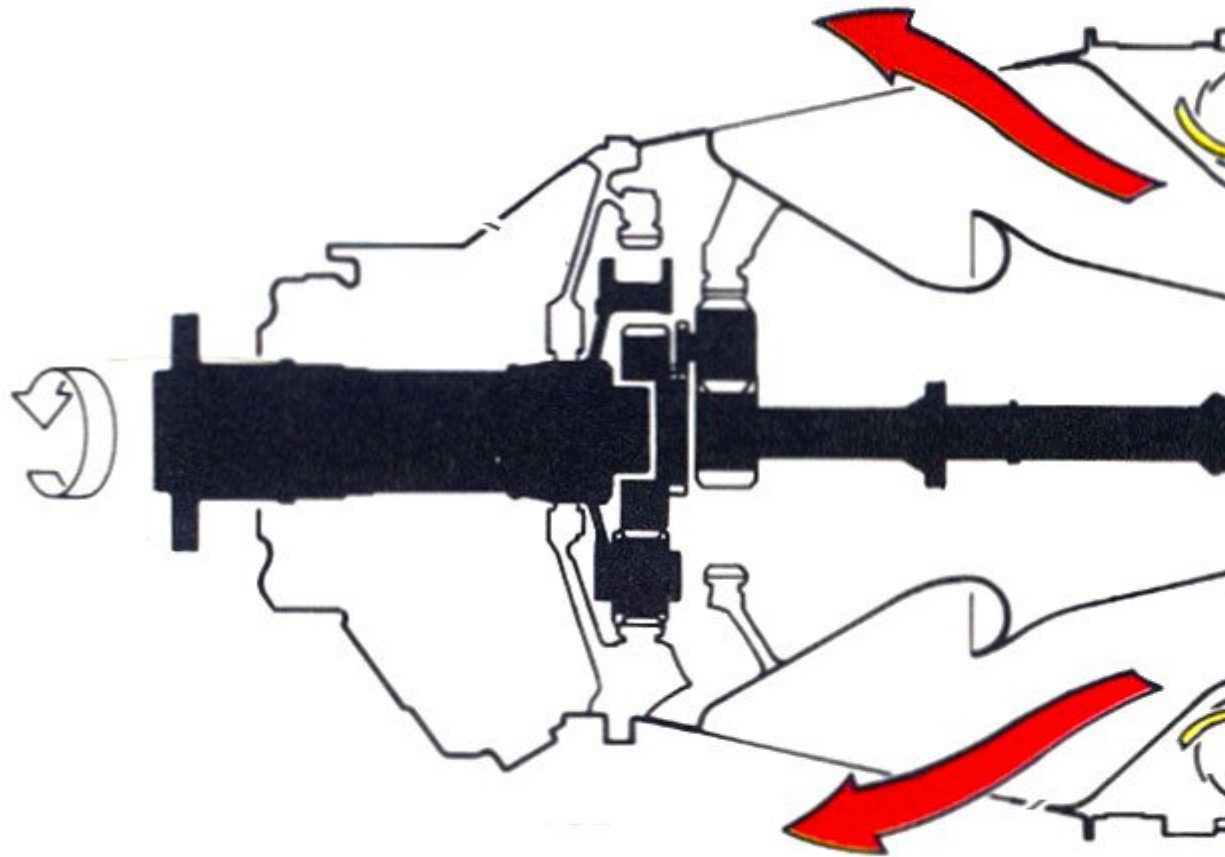

- (a) Fixed turbine type.
- (b) Triple shaft type.
- (c) Free turbine type.

If choice c is selected set score to 1.

67. What is the advantage of a parallel spur gear train?

It is...

- (a) mechanically simple and therefore relatively cheap to manufacture.
- o (b) mechanically complex but relatively cheap to manufacture.
- o (c) mechanically simple but relatively expensive to manufacture.

If choice a is selected set score to 1.

68. On a typical free turbine turboprop engine the propeller control lever is connected to the...

- o (a) constant speed fuel mixing unit.
- (b) propeller governor.
- o (c) fuel control unit.

If choice b is selected set score to 1.

69. Overspeed is the condition in which the actual engine speed is higher than the desired engine speed set.

How is this prevented?

- o (a) Only by throttle being retarded.
- (b) By overspeed governor.
- o (c) Centrifugal forces of the fan.

If choice b is selected set score to 1.

70. The drive systems are equipped with over running clutches that allow the pilot to perform auto-rotation descent in case of total power loss.

This is true for a...

- (a) turbo-shaft engine on a helicopter.
- o (b) hydro shaft system.
- o (c) reduction gear system from an axial flow bypass engine.

If choice a is selected set score to 1.

71. The most commonly used turbo-shaft engines today are from the...

- (a) free-turbine type.

- (b) single shaft type.
- (c) fixed-turbine type.

If choice a is selected set score to 1.

72. What is a turbo-shaft engine?

- (a) A turbine that drives a high speed ultra high bypass compressor.
- (b) A gas turbine engine that delivers power through a rotating shaft.
- (c) Axial flow compressor with a propeller drive system, used in large commercial aircraft

If choice b is selected set score to 1.

73. Turbo-shaft engines are used in many applications, but in the aviation industry they are mostly used in?

- (a) helicopters.
- (b) ultra light aircraft
- (c) commercial airlines.

If choice a is selected set score to 1.

74. There are two separate APU protective shutdown systems in the ECU.

They are...

- (a) discrete and digital.
- (b) analog and digital.
- (c) analog and discrete.

If choice b is selected set score to 1.

75. The APU fuel system receives fuel from...

- (a) external fuel source during operation.
- (b) ground support system.
- (c) the airplane wing tanks through a shrouded line.

If choice c is selected set score to 1.

76. The auxilliary power unit or APU is a small gas turbine engine fitted to aircraft.

They can provide...

- (a) hydraulic pressure.

- (b) electric power and pneumatic duct pressure.
- o (c) electrical power for the inflight entertainment system.

If choice b is selected set score to 1.

77. The APU control unit (ECU) completely controls...

- (a) start and acceleration.
- o (b) automatic selection of air source, no pilot interface needed, including start.
- o (c) start and acceleration including automatic selection of air.

If choice a is selected set score to 1.

78. The aft engine mount transfers...

- o (a) side loads only however it allows for engine growth.
- (b) torsional, vertical and side loads to the pylon.
- o (c) thrust loads to the wing

If choice b is selected set score to 1.

79. When you need no overhead crane or other external hoist devices to change an engine.

This is a...

- o (a) Chain hoist equipment.
- o (b) Single hoist equipment.
- (c) Bootstrap equipment.

If choice c is selected set score to 1.

80. The pylon transmits engine loads to the wing through the...

- o (a) wing spars, front and rear.
- (b) forward bulkhead and aft mount bulkhead.
- o (c) lower wing surface.

If choice b is selected set score to 1.

81. In order to give a powerplant a good aerodynamic profile which blends smoothly with the aircraft, it must be...

- (a) enclosed within a cowling.

- (b) enclosed within the wing fairing.
- (c) separate of the wing to ensure aerodynamic efficiency.

If choice a is selected set score to 1.

82. This system operates on the rate-of-temperature-rise principle.

What system is this?

- (a) Pressure relief system monitoring.
- (b) Thermal switch system
- (c) Thermocouple fire detector system

If choice c is selected set score to 1.

83. Turbine case cooling is used to....

- (a) improve service life of the high pressure compressor.
- (b) reduce turbine rotor vane clearances and improve engine efficiency.
- (c) improve gasturbine starting characteristics at high altitude.

If choice b is selected set score to 1.

84. Fire is one of the most dangerous threats to an aircraft.

How are the potential fire zones of all multi engine aircraft which are currently produced, protected?

- (a) by fire funnels.
- (b) by a portable fire protection system.
- (c) by a fixed fire protection system.

If choice c is selected set score to 1.

85. Which answer is the best description for: "The fire detection system which uses a single wire surrounded by a continuous string of ceramic beads in an Iconel tube"?

- (a) Graviner
- (b) Fenwall
- (c) Kidde

If choice b is selected set score to 1.

86. What major consideration must be observed in positioning the aircraft when preparing for a high power run?

- (a) Position on firm concrete with the jet exhaust directed away from other aircraft and buildings
- o (b) Make sure the tail of the aircraft is tie down. Regardless of wind direction.
- o (c) Reduce the fuel load because of high power stress and flaps must be retracted

If choice a is selected set score to 1.

87. What is the most important engine instrument indication to monitor during a start of a turbine engine?

- o (a) Oil pressure.
- (b) Exhaust gas temperature.
- o (c) Engine oil temperature.

If choice b is selected set score to 1.

88. Routine checks are made to compare the current performance of the engine with its test-cell performance.

Why?

- o (a) It is strictly a management tool to ensure personnel are doing their job.
- (b) This trend monitoring is a system of continuous in flight comparison of engine performance parameters with a base line of these same parameters.
- o (c) Monitoring is a system of annual requirement to compare engine performance parameters with a base line of these same parameters.

If choice b is selected set score to 1.

89. One procedure that has improved efficiency is the built-in provision for inspecting the inside of the engine without disassembling it.

This is performed by...

- o (a) large access ports installed through each module of the engine.
- o (b) xray of the internal parts on a regular time frame.
- (c) borescope equipment.

If choice c is selected set score to 1.

90. To clean the gas path, washing with pure water is to recover the...

- (a) EGT margin.
- o (b) low EPR output.
- o (c) gas path through the exhaust.

If choice a is selected set score to 1.

91. Which manual describes the correct procedure to install an engine after storage?

- (a) Maintenance manual.
- o (b) Engine manual.
- o (c) Flight manual.

If choice a is selected set score to 1.

92. When the engine is returned in service after preservation, the engine fuel system should

- o (a) get a complete engine ground run.
- o (b) be static drained.
- (c) be completely flushed by motoring the engine.

If choice c is selected set score to 1.

If assessment score is 0% to 100% Feedback